

HK-68C71A 9B7 CBH5BGDFC 4F5FMB; CFA5HC B5B9 6G 6A #H88 47 CB: 49B7 9 HK G
 8C 71 A 9BH6G 6-97 HHC F9H FB I DC B F6 I 9G H 9 B: CFA 5HC B 7 CBH5 B98 < 9F9B 6BC H69
 I 098 # 5B M K 5 M8 9F A 9B H5 @ HC HK 9 B H F 9 G C C: < MDC K 9 *

BC H: D B < C @ 7 @ 5 F 5 B 7 9 A 5 7 < B 9 8 ' H C ' G I # 5 B G = 6 (" & 8 - # A -
 DC F H H F 9 5 8 G A 5 7 < B 9 8 ' H C ' G C % % & * ! % C H 9 F H F 9 5 8 G A 5 7 < B 9 8 ' H C ' 7 @ 5 G G & 5 # 6
 ; 9 B 9 F 5 @ 8 A 9 B G C B G G I # H C & * , ! a ? I B @ 9 G C H K 9 F K 6 9 G H 5 H 9 8
 ; 9 B 9 F 5 @ G I F : 5 7 9 A 5 7 < B B ; ' H C ' G C % % & \$
 : C F 7 9 7 5 @ I @ 5 H C B G 5 F 9 H K 9 C F 9 H 7 5 @ A 5 L A I A " 5 @ C K I D ' H C ' & \$ I : C F ' @ C G 9 G

C D 9 F 5 H B ; ' 7 C B 8 H C B G
 A 5 L ' D F 9 G G I F 9 & % \$ ' 6 5 F
 D I G < : C F 7 9 4 ' & % \$ ' 6 5 F * * (+ ? [
 D I @ : C F 7 9 4 ' & % \$ ' 6 5 F (* + ? [
 : @ - 8 < M B F 5 I @ 7 ' C - @ J ; (*

7 M @ B 8 9 F : 5 7 H C F ' C : ' G 5 : 9 H M 5 H & % \$ ' 6 5 F		
GF 9 G G 5 F 9 5	G 5 : 9 H M : 5 7 H C F	7 C A A 9 B H
D G C B ' D I @ C : :	& " \$. %	
FC 8 ' A C I B H D I @ C : :	(" .) . %	
FC 8 ' 6 I 7 ? @ 9	3.7 . %	5 H A 5 L 9 L H 9 B G C B
6 5 G 9 ' A C I B H	' * * \$. %	
FC 8 ' A C I B H	(" & + . %	
6 5 F F 9 @	' " +) . %	< C C D ' G F 9 G G
D B G	' * *) . %	

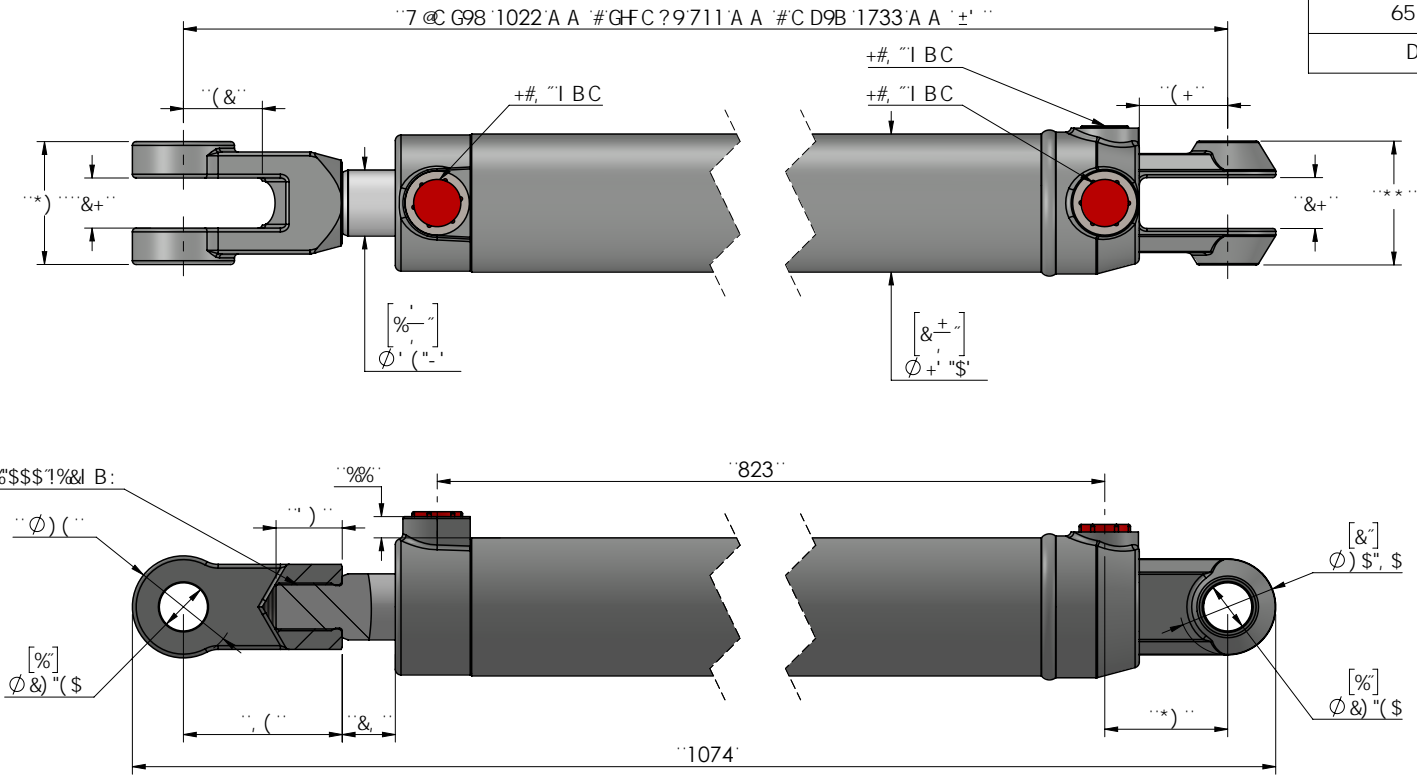

7 M @ B 8 9 F ' G D 9 7 ÷ 7 5 H C B G			
7 @ G 9 8	1022 A A	DC F H G	+ # , ' I B C
G F C ? 9	7 1 1 ' A A	6 5 F F 9 @	& 7 / 8 " H 6 9 3 / 1 6 " K 5 @
C D 9 B	1 7 3 3 ' A A	< 9 5 8 ' 7 @ J 6	+ - \$ % \$ + 5
G H 5 B 8 ' C I H	& ' A A	FC 8 ' 7 @ J 6	: 7 \$ \$ \$ \$ (\$ % \$ &
FC 8	% " +) ' I ? % \$ ()	K 9 ÷ < H	% 8 . 0 ? [
6 C F 9	&) \$ "	D 5 - B H B ;	F 9 : 9 F ' H C ' E I C H 9

OSOP-VA UOP-AMUO				
AEUUXAS OAO				
Ó			ÚPÓAVIzO	5 (
CE			ÚOASO	% (
€	G 6 6 6 6 6 I	T R U V U P O	G < 9 9 H C : % # %	
ÚOX	ÓABO	OUB PA OP-OOSOO	ÚOT AÚS	

G \$ \$ \$ ' &)	
8 9 G 7 F - D H C B	
7 M @ B 8 9 F ' &) \$ " 6 C F 9 L 7 1 1 ' A A ' G P ' 5 D C F H - \$ 8 9 : H C ' D B	
D 5 F H B C "	8 K : ' B C "
G \$ \$ \$! &) 1 7 1 1 ! (\$! 5 1 \$ \$ \$	G \$ \$ \$! &) 1 7 1 1 ! (\$! 5 1 \$ \$ \$ B - A